

SECTION : 9I

WATERLEAKS

TABLE OF CONTENTS

| | |
|---|--|
| SPECIFICATIONS 9I-1 RECOMMENDED MATERIALS FOR WATERLEAK REPAIRS 9I-1 WATERTEST STAND SPECIFICATIONS 9I-1 DIAGNOSIS 9I-2 | WATERLEAK DIAGNOSIS 9I-2 MAINTENANCE AND REPAIR 9I-5 ON-VEHICLE SERVICE 9I-5 WATERLEAK REPAIR 9I-5 |
|---|--|

SPECIFICATIONS

RECOMMENDED MATERIALS FOR WATERLEAK REPAIRS

| Leak Areas | Repair Materials |
|----------------------------|---|
| Windshield, back window | Urethane adhesive, caulking kit, or the equivalent |
| Metal joints | Brushable seam sealer which can be painted |
| Ventilation ducts | 3M™ Auto Bedding and Glazing Compound or the equivalent |
| Small cracks and pin holes | 3M™ Drip-Check Sealer or the equivalent |
| Large holes | 3M™ Automotive Joint and Seam Sealert |
| Weatherstrips | 3M™ 08011 Weatherstrip Adhesive or the equivalent |
| Bolts, studs, and screws | Strip caulk |

WATERTEST STAND SPECIFICATIONS

| Application | Description |
|---|---|
| Nozzle Type | Full jet spray nozzle #1/2 GG-25 or equivalent with a 60° included angle |
| Nozzle Height | Approximately 1,600 mm (63.0 in.) from the floor |
| Volume of Flow | 14L (3.7 gal) per minute |
| Pressure | 155 kPa (22.5 psi) measured at the nozzle |
| Windshield and A-Pillar Test Stand Position | Approximately 30° down, 45° toward the rear, and aimed at the corner of the windshield |
| B-Pillar Test Stand Position | Approximately 30° down, 45° toward the rear, and aimed at the center of the rear door |
| Back Window and Rear Deck Lid Test Stand Position | Approximately 30° down, 30° toward the front and aimed approximately 610 mm (24.0 in.) from the corner of the back window |

DIAGNOSIS

WATERLEAK DIAGNOSIS

The repair of waterleaks in the body requires proper testing and diagnosis. Repair waterleaks by adjusting the misaligned parts and using the proper repair materials. First, determine what conditions cause the leak. For example, the leak may occur only when the vehicle is parked on an incline, or water may appear only in the spare tire compartment. Second, test the area for the source of the leak using the following testing methods. If the general leak area is found, determine the exact entry point of the leak by using a water hose or an air hose. If the general leak area is not obvious, use the watertest stands to determine the area of the leak. It may be necessary to remove some interior trim panels or some parts in order to locate the leaks.

Important : It is necessary to find the origin of all the leaks before making any repairs. Random repairs may stop the leak only temporarily and may make future repairs more difficult. Continue localized testing in the general area in order to ensure that all leaks are found.

Generalized Testing

1. Set up the watertest stands.

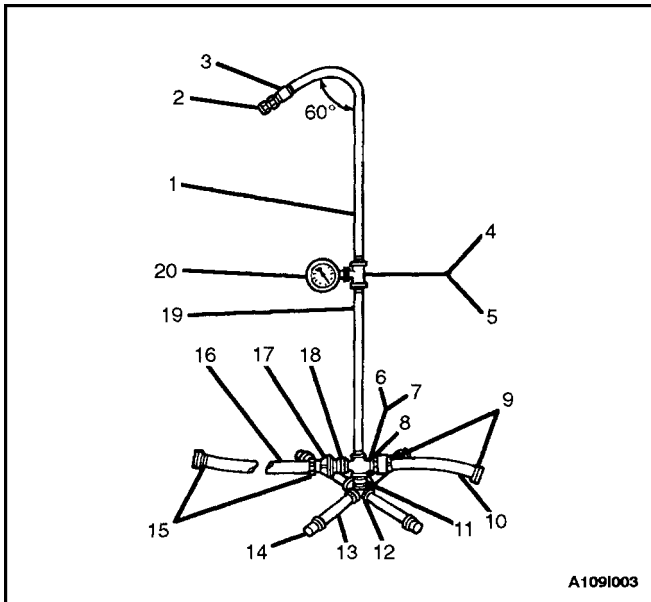

- 1) 1/2-inch by 36-inch Pipe

- 2) Full-jet Spray Nozzle #1/2 GG-25 or Equivalent Nozzle Height at 1,600 mm to the Floor
- 3) 1/2-inch Coupling
- 4) 1/2-inch by 1/2-inch by 1/4-inch Reducing T (Right Only)
- 5) 1/2-inch Coupling (Left Only)
- 6) 1/2-inch Cross (Right Only)
- 7) 1/2-inch Tee (Left Only)
- 8) 5/8-inch Input Hose (2 Feet Long, Right Only)
- 9) 1/2-inch Pipe-to-Hose Nipple (Right Only)
- 10) 1/2-inch Close Nipple
- 11) 1/2-inch Cross with Weld-on 1/2-inch Cap
- 12) 1/2-inch by 12-inch Nipple
- 13) 1/2-inch Cap
- 14) 5/8-inch Female Hose Coupling
- 15) 5/8-inch Cross Hose (12 Feet Long)
- 16) 5/8-inch Hose Quick Connect
- 17) 1/2-inch Pipe-to-Hose Nipple
- 18) 1/2-inch by 30-inch Pipe (Straight)
- 19) 1/4-inch Water Pressure Gauge (Right Only)

2. Set up the watertest stand leak test.

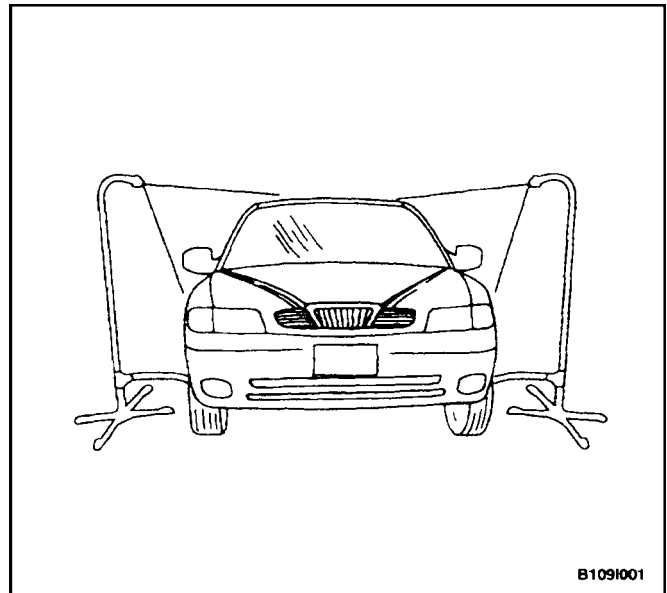

3. Perform the watertest stand leak test. Refer to "Watertest Stand Specifications" in this section.
4. If the local water pressure does not allow the required water pressure of 155 kPa (22.5 psi), move both stands closer to the vehicle so that the water spray overlaps.

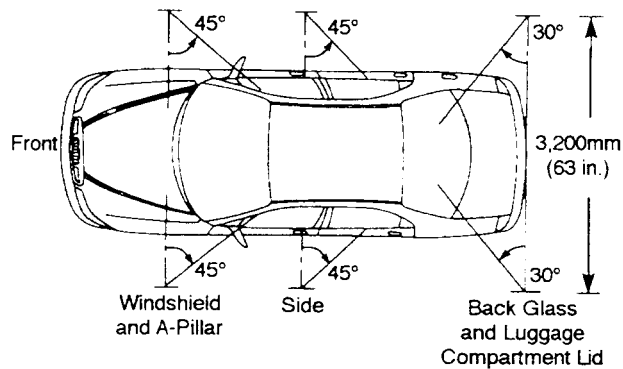

B109I002

Localized Testing (Spot Test)

1. Do localized testing with a water hose or an air hose.
2. Begin testing by spraying the air or the water at the base of the suspected leak area. Continue spraying the air or the water upward until the leak is found.

Water Hose Test

1. Place another person inside the vehicle in order to detect the location of the leak.
2. Use a water hose without a nozzle.

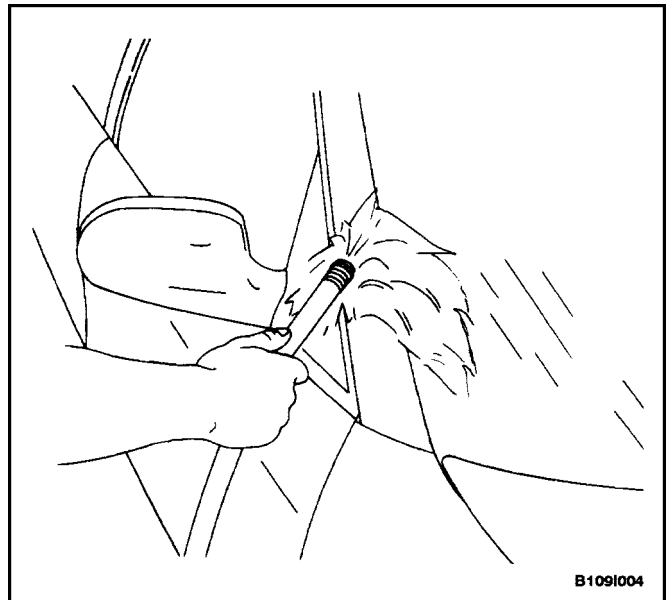

B109I004

3. Begin spraying the water at the base of the suspected leak area. Continue spraying the water upward until the leak is found.

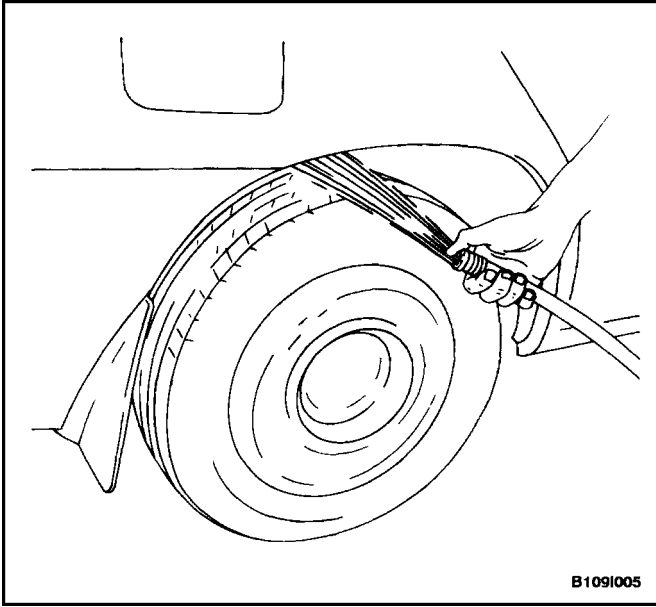

Air Hose Test

1. Apply soapy water to the outside of the vehicle in the suspected leak area.

2. Blow air from inside the vehicle. The air pressure should not exceed 205 kPa (29.7 psi).
3. Determine the location of the leaks from the bubbles formed in the soapy water.

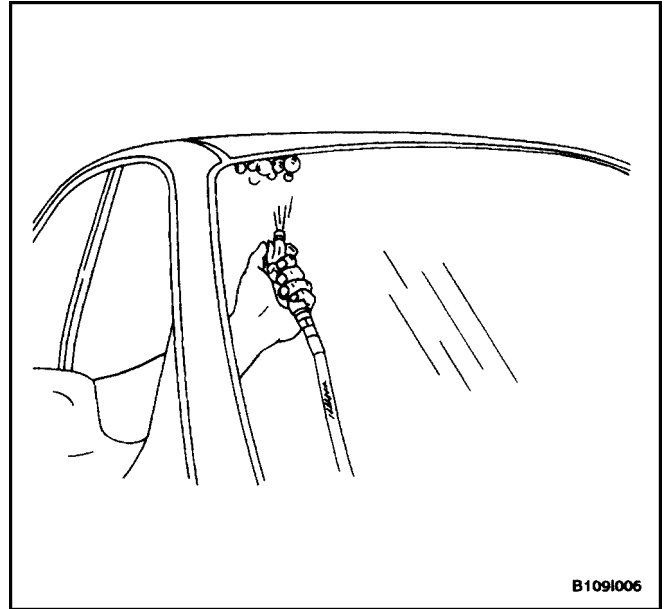

MAINTENANCE AND REPAIR

ON-VEHICLE SERVICE

WATERLEAK REPAIR

Some waterleaks around the glass can be repaired without removing the glass.

Important : This type of repair may be used only for urethane-installed glass.

1. Remove the reveal molding in the area of the leak. It may be necessary to remove the garnish molding or the trim strip lace in order to locate the leak.
2. While spraying water over the leak area, carefully push the glass outward in order to determine the size of the leak.
3. Mark the location of the leak.
4. Use water to clean any dirt from the area. Dry the area with an air hose.
5. Using a sharp knife, trim off the uneven edges of the adhesive caulking material around the leak for a distance of 75 to 100 mm (3 to 4 inches) on both sides of the leak.
6. Using a sharp knife, trim off the uneven edges of the adhesive material around the leak 75 to 100 mm (3 to 4 inches) on both sides of the leak.

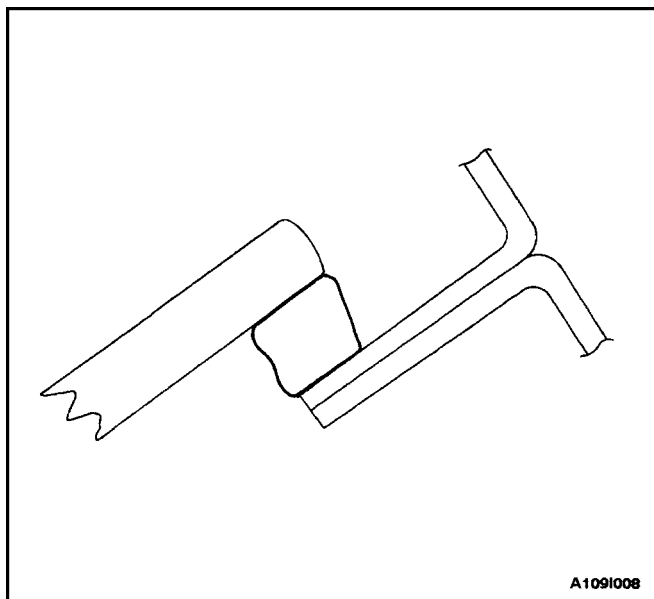
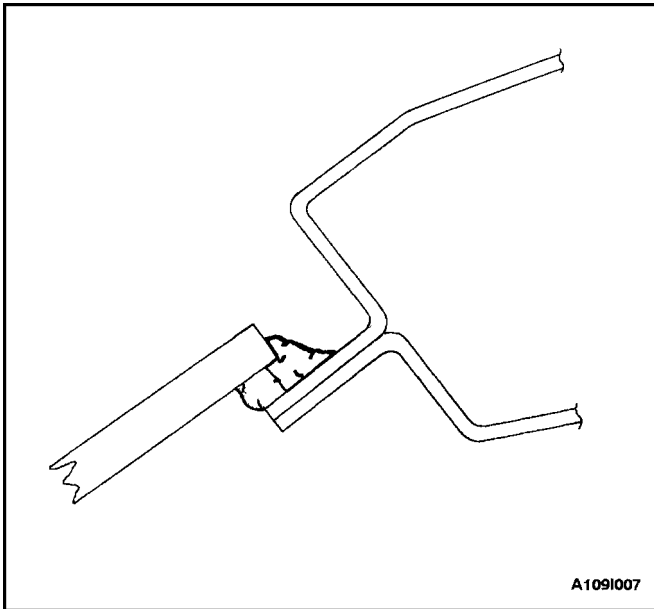

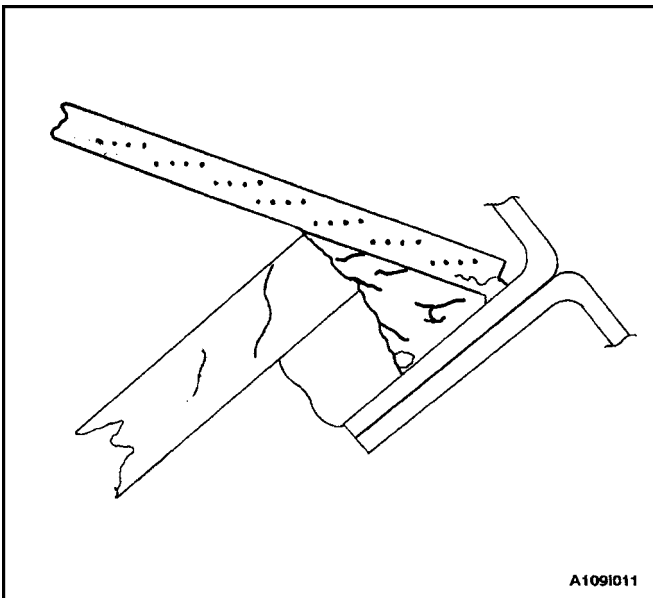
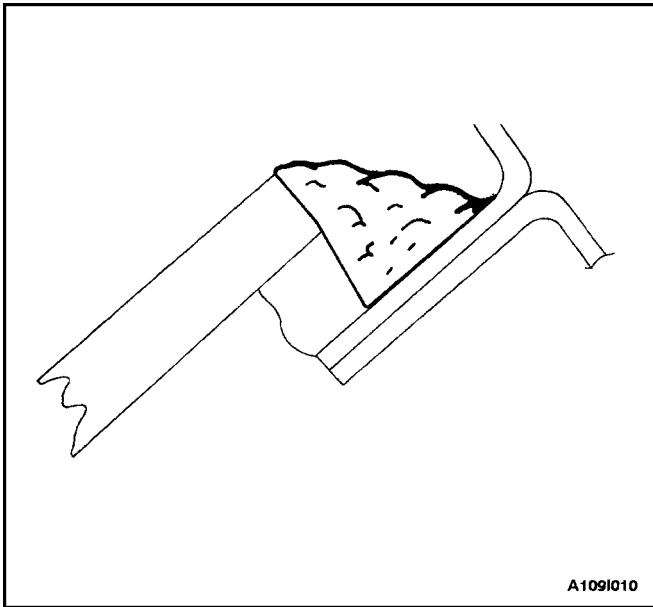
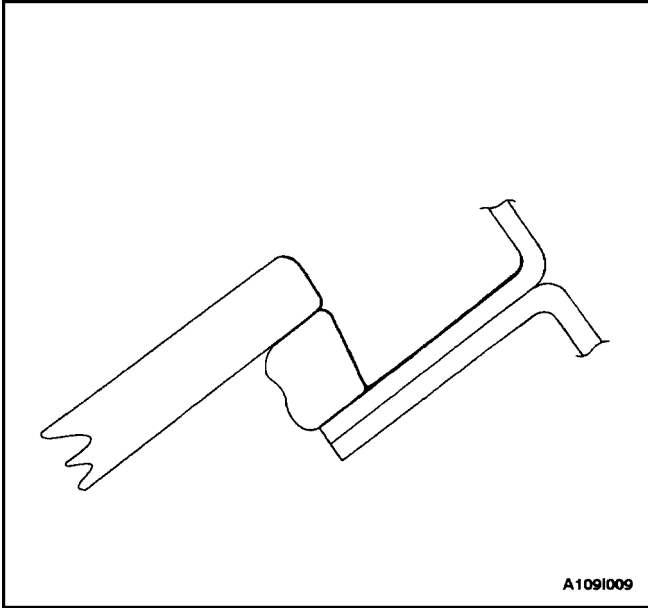

7. Prime the trimmed area with the primer.

8. Allow the primer to dry for 5 minutes.

9. Apply the adhesive over the leak and for a distance of 75 to 100 mm (3 to 4 inches) on both sides of the leak.

10. Immediately after applying the adhesive, use a flat stick or a similar tool to work the adhesive into the leak area and into the joint between the original material and the vehicle body in order to ensure a watertight seal.

11. Spray warm or hot water over the repaired area in order to determine if the leak was repaired. Do not run a heavy stream of water directly on the freshly-applied adhesive.

12. Install the trim strip lace if it was removed.

13. Install the garnish molding if it was removed.

14. Install the reveal molding.

Important : After the completion of any waterleak repair, re-test the area using the watertest stands. Do not use localized testing procedures on the newly-repaired areas, as the repair material may dislodge under abnormal pressure.